

Chapter 1 The discovery of the electron

1.1 Thermionic emission of electrons

Learning objectives:

- What are cathode rays and how were they discovered?
- Why does the gas in a discharge tube emit light of a certain colour?
- How is a beam of electrons produced in a vacuum tube?

Cathode rays

Discharge tubes used in colourful advertising displays were first developed by William Crookes in the 1870s. He was able to reduce the pressure of the gas in a gas-filled glass tube by removing most of the gas from the tube using a vacuum pump. He discovered that gases at sufficiently low pressure in such tubes conduct electricity and emit light of a characteristic colour. For example, neon gas in such a tube emits red light.

Changing the gas pressure causes the glow of light to come from different parts along the tube, as shown in Figure 1. Investigations into the cause of the glow showed that:

- the glowing gas near the anode, the positive column, was easily distorted when a magnet was brought near the tube. This observation showed charged particles move through the gas when it conducts electricity.
- radiation from the direction of the cathode forced ‘a paddle wheel’ placed in the tube to rotate. The radiation was referred to as **cathode rays**. Placing a magnet near the tube stopped the paddle wheel rotating by deflecting the cathode rays away from it.

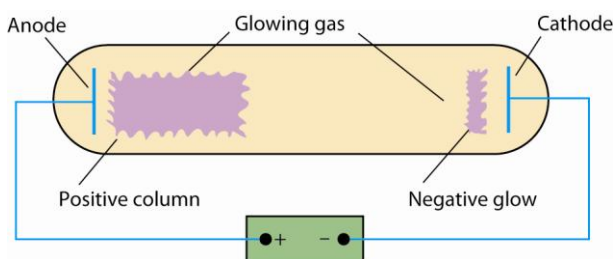

Figure 1 A discharge tube

Further tests showed that the cathode rays to be negatively charged particles. Exactly what cathode rays are puzzled scientists for over 20 years until J J Thomson carried out a series of experiments and proved that the negative particles are the same, regardless of which gas is used in the tube. The cathode ray particles were referred to as **electrons**.

The emission of light from a discharge tube

The emission of light from a discharge tube happens because the voltage applied to the tube is so high that it pulls electrons out of some of the gas atoms in the tube. In other words, some of the

gas atoms in the tube are ionised. Positive ions created near the cathode are attracted onto the cathode surface, causing free electrons from the cathode surface to be emitted.

- The electrons from the cathode are accelerated towards the anode and collide with gas atoms causing them to be ionised. The glowing gas near the cathode, the ‘negative glow’, is due to photons emitted when some of the positive ions and electrons produced by ionisation recombine.
- Some of the electrons pulled out of the gas atoms do not recombine and are attracted to the anode and therefore further move away from the cathode – hence the term ‘cathode rays’. These electrons move towards the anode and cause **excitation by collision** of gas atoms in the tube. The positive column of glowing gas is due to de-excitation of these excited gas atoms.

The processes of recombination and de-excitation result in the emission of photons of visible and ultraviolet light.

Link

Look back at *AS Physics A* Topic 3.3 Ionisation and de-excitation; photons and energy levels.

The principle of thermionic emission

Thermionic emission is a much simpler way of producing an electron beam than using a discharge tube. When a metal is heated, some of the electrons that move about freely inside the metal (referred to as ‘free’ or ‘conduction’ electrons) gain sufficient kinetic energy to leave the metal at its surface. In practice, the metal is a wire filament which is heated by passing an electric current through it. The filament or ‘cathode’ is at one end of an evacuated glass tube which has a metal plate or ‘anode’ at the other end. This is shown in Figure 2.

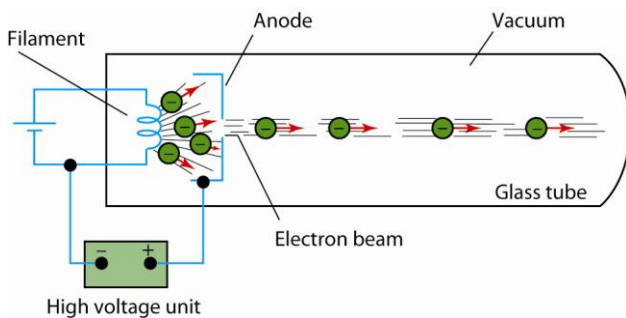

Figure 2 Thermionic emission

The electrons emitted from the filament are attracted to the anode by connecting a high voltage power supply between the anode and the cathode, with the anode positive relative to the filament. There are no gas molecules in the tube to stop the electrons, so the electrons are accelerated to the anode where they pass through a small hole to form a narrow beam.

The **speed** of each electron passing through the hole can be worked out by equating:

- the work done by the pd V between the anode and the cathode on each electron = eV , where e is the charge of the electron, and
- the kinetic energy of each electron passing through the hole = $\frac{1}{2}mv^2$, where v is the speed of each electron at this position.

Since the work done on each electron increases its kinetic energy from a negligible value at the cathode, the speed, v , of each electron on leaving the anode is given by

$$\frac{1}{2}mv^2 = eV$$

Notes

- The speed of each electron in the beam from the anode is given by the above equation. This is because the electric field between the anode and the cathode does not act on the electrons once they have passed through the hole in the anode. Their kinetic energy does not change after leaving the anode.
- The above equation assumes that:
 - each electron starts from the filament with negligible kinetic energy in comparison with the work done on it by the accelerating pd V
 - the speed of the electrons in the beam, v , is much less than the speed of light in free space, c , so the non-relativistic formula for kinetic energy ($\frac{1}{2}mv^2$) applies.

Links

The equation **work done** = **charge** \times **pd** was looked at in Topic 4.2 of *AS Physics A*.

The equation **kinetic energy** = $\frac{1}{2}mv^2$ was looked at in Topic 10.2 of *AS Physics A*.

Worked example

$$e = 1.60 \times 10^{-19} \text{ C}$$

Calculate the speed of an electron after it has been accelerated from rest through a pd of 5000 V.

The rest mass of an electron = 9.11×10^{-31} kg.

Solution

$$\text{Rearranging } \frac{1}{2}mv^2 = eV \text{ gives } v = \sqrt{\frac{2eV}{m}} = \sqrt{\frac{2 \times 1.60 \times 10^{-19} \times 5000}{9.11 \times 10^{-31}}} = 4.19 \times 10^7 \text{ ms}^{-1}$$

AQA Examiner's tip

Be careful not to mix up the symbols v and V .

Summary questions

- When a suitable pd is applied between the anode and the cathode of a discharge tube, explain why the gas in the tube conducts electricity and emits light.
- Explain why:
 - the glowing gas in a discharge tube is distorted when a magnet outside the tube is placed near the glowing gas
 - the negative particles in a discharge tube are identical, regardless of the gas in the tube.
- Look at Figure 2, and state the function of:
 - the cell connected to the filament

- ii** the high voltage unit.
 - b** Explain why the tube in Figure 2 must contain a vacuum.
- 4** Calculate the speed of an electron after it has been accelerated in a vacuum tube from rest through a pd of 4000 V. Give your answer to 3 significant figures.

1.2 Deflection of an electron beam

Learning objectives:

- How can electron beams be controlled and deflected?
- What happens to the deflection of an electron beam if the speed of the electrons is increased?
- How can we determine the speed of the electrons in a beam?

An electron beam can be deflected by an electric field or a magnetic field. By adjusting the strength of the field in each case, the extent of the deflection can be controlled. In this topic, we will consider the principles behind the use of electric and magnetic fields to control an electron beam before moving on in the next topic to consider how these principles may be used to determine the specific charge e/m of the electron.

Using a uniform electric field

Figure 1 shows a glass vacuum tube in which an electron beam is produced so that it can be deflected by an electric field or a magnetic field or both.

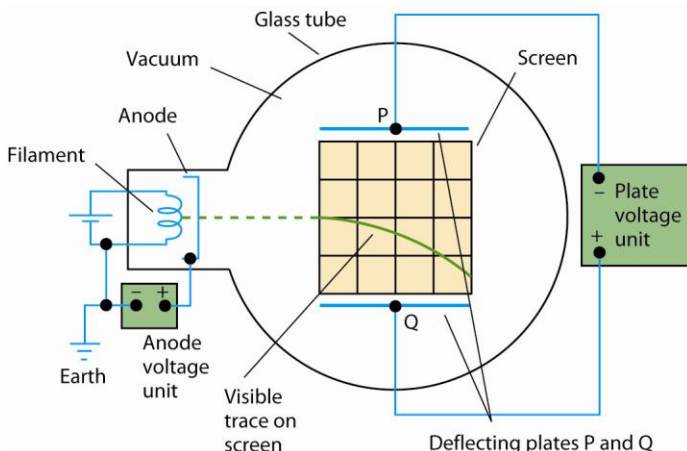

Figure 1 Deflecting electrons

The electric field used to deflect the beam is produced in Figure 1 by applying a constant pd between the metal deflecting plates P and Q. The beam enters the field at right angles to the field lines and is deflected towards the positive plate.

The force on each electron in the field is constant in magnitude and direction because the field is uniform so the beam curves in a parabolic path (just as a projectile projected horizontally does). The fluorescent screen in the tube enables the path of the beam to be observed and measured.

If the pd between plates P and Q is V_p , the force F on each electron is given by the equation

$$F = eE = \frac{eV_p}{d}$$

where d is the perpendicular distance between plates P and Q, and $E (= V_p/d)$ is the electric field strength between the plates.

Notes

- 1 The acceleration of each electron towards the positive plate, $a = \frac{F}{m} = \frac{eV_p}{md}$, where m is the mass of the electron.
- 2 The time taken, t , by each electron to cross the field = $\frac{L}{v}$, where L is the length of each plate and v is the initial speed of the electron on entry to the field. This is the horizontal component of the electron's velocity in the field as it has no horizontal acceleration.
- 3 The deflection, y , of the electron on leaving the field is given by the equation $y = \frac{1}{2}at^2$. The deflection may be measured directly from the trace on the screen in the tube. If the speed of the electrons is increased (by increasing the anode voltage), each electron spends less time in the electric field so the deflection is less.
- 4 The above equations can be combined to show that the deflection y is directly proportional to the plate pd.

Link

Horizontal projection was looked at in Topic 8.7 of *AS Physics A*.

Using a uniform magnetic field

A uniform magnetic field can be applied to the electron beam by placing a pair of large circular coils coaxially either side of the tube such that the plane of each coil is parallel to the screen, as shown in Figure 2.

When the two coils are connected in series and a current is passed through them in the same direction, a uniform magnetic field perpendicular to the screen is produced. The magnetic flux density can be varied by varying the current in the coils.

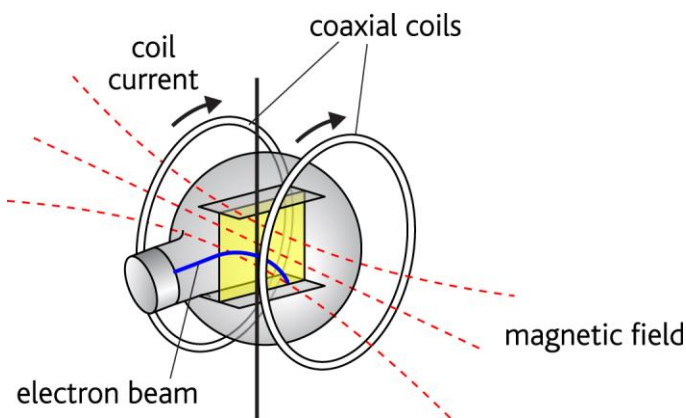

Figure 2 Using coaxial coils

Each electron in the beam experiences a force due to the magnetic field at right angles to the direction of motion of the electrons and to the direction of the magnetic field. In accordance with Fleming's left-hand rule, the result is that each electron is forced on a circular path so the beam traces a circular arc on the screen.

The force F on each electron in the field is given by

$$F = Bev$$

where B = the magnetic flux density of the magnetic field and v = the speed of the electron.

Notes

The direction of the magnetic force on each electron is perpendicular to the direction of velocity of the electron. Therefore,

- the magnetic force does no work on the electron so its speed remains constant,
- the electron moves on a circular path of radius r with a centripetal acceleration $a = \frac{v^2}{r}$

Using $F = ma$ therefore gives $Bev = \frac{mv^2}{r}$

Hence the radius of curvature of the beam path, $r = \frac{mv}{Be}$

The equation shows that the radius of the beam can be increased by:

- increasing the anode pd so the electron speed v is increased, or
- decreasing the coil current so the magnetic flux density is decreased.

Balanced fields

With a magnetic field applied as outlined above to deflect the beam downwards, the deflection can be cancelled out by applying an electric field of suitable strength with the top plate P **positive** relative to the lower plate Q.

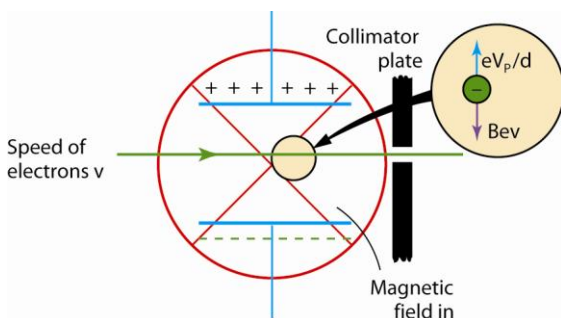

Figure 3 *Balanced fields*

- If the electric field is too strong, the beam will be deflected upwards because the magnetic force acting downwards on each electron is weaker than the electric force acting upwards.
- If the electric field is too weak, the beam will be deflected downwards because the magnetic force acting downwards on each electron is stronger than the electric force acting upwards.

The beam passes through the fields without being deflected when the electric force $\frac{eV_p}{d}$ is equal and opposite to the magnetic force Bev on each electron. The two fields may be said to be 'balanced' because they produce zero resultant force on each electron. In this situation, the speed v of each electron is given by

$$Bev = \frac{eV_p}{d}$$

Rearranging this equation gives $v = \frac{V_P}{Bd}$

Worked example

$$e = 1.60 \times 10^{-19} \text{ C}$$

A beam of electrons is directed horizontally into a uniform electric field which acts vertically downwards. The electric field is due to a pd of 4500 V applied between two parallel deflecting plates 60 mm apart. With the electric field on, a uniform magnetic field is applied to the beam perpendicular to the electric field and to the initial direction of the beam. The magnetic flux density is adjusted to a value of 2.4 mT so the beam is undeflected.

- a State the direction of:
 - i the electric force
 - ii the magnetic force.
- b Calculate the speed of the electrons as they pass through the electric and magnetic fields.

Solution

- a i The electric force is vertically upwards (in the opposite direction to the electric field lines because the electron has a negative charge).
 - ii The magnetic force is vertically downwards (in the opposite direction to the electric force).

- b Using $Bev = \frac{eV_P}{d}$ gives speed $v = \frac{V_P}{Bd} = \frac{4500}{2.4 \times 10^{-3} \times 60 \times 10^{-3}} = 3.2 \times 10^7 \text{ m s}^{-1}$

Summary questions

- 1 In Figure 1, if the top plate is at a negative potential relative to the lower plate, state the direction of:
 - a the electric field between the plates
 - b the force on an electron in the field
 - c the acceleration of an electron in the field.
- 2 An electron beam is directed horizontally into a uniform electric field which acts vertically downwards. Explain why the electron beam curves upwards with increasing speed.
- 3 An electron beam is directed horizontally into a uniform magnetic field that is perpendicular to the initial direction of the beam. Explain why the beam curves round in a vertical circle at constant speed.
- 4 A beam of electrons moving at a speed of $2.8 \times 10^7 \text{ m s}^{-1}$ passes through perpendicular electric and magnetic fields without being deflected. The magnetic field has a flux density $3.2 \times 10^{-3} \text{ T}$. Calculate the strength of the electric field.

1.3 Use of electric and magnetic fields to determine e/m

Learning objectives:

- How can e/m be measured?
- What measurements are needed to determine e/m ?
- What was the significance of the first accurate determination of e/m ?

The determination of the specific charge of the electron, e/m

After the discovery of cathode rays, J J Thomson in 1895 measured the specific charge, $\frac{e}{m}$, of the electron (i.e. its charge e divided by its mass m , sometime referred to as its charge/mass ratio). Using a deflection tube, he measured the speed of the electrons by passing them through balanced electric and magnetic fields, adjusted so the electron beam was undeflected. The speed of the electrons could then be calculated, as explained in Topic 1.2, by measuring the deflecting pd V_P , the plate spacing d and the magnetic flux density B and using the equation $v = \frac{V_P}{Bd}$.

With one of the fields switched off, the deflection of the beam due to the field still on was then measured and used with the known value of the initial speed to determine $\frac{e}{m}$.

Using the electric field only, as shown in Figure 1, with electrons of known speed v

- the time taken, t , for the electrons to travel the length L of the deflecting plates = $\frac{L}{v}$
- the acceleration, a towards the positive plate = $\frac{2y}{t^2}$ (from $y = \frac{1}{2} at^2$)

Since the acceleration $a = \frac{eV_P}{md}$, rearranging this equation gives $\frac{e}{m} = \frac{ad}{V_P}$

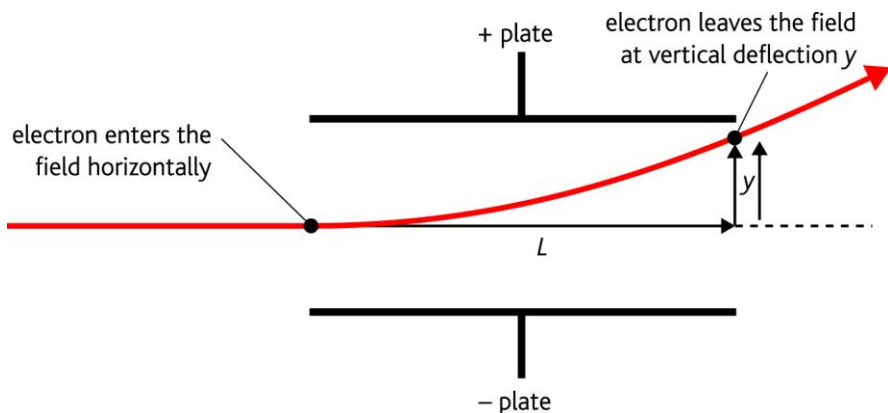

Figure 1 Deflection by a uniform electric field

Link

Projectile motion was looked at in Topic 8.7 of AS Physics A.

Worked example

Electrons moving at a constant speed are directed horizontally into a uniform electric field due to two parallel plates of length 60.0 mm. The plates are spaced 50.0 mm apart and have a pd of 3000 V between them. The electrons are deflected by 22.0 mm as a result. When a uniform magnetic field of flux density 2.05 mT is applied at right angles to the beam and the electric field, the beam is undeflected. Calculate the specific charge e/m of the electron.

Solution

$$\text{The speed of the beam, } v = \frac{V_p}{Bd} = \frac{3000}{2.05 \times 10^{-3} \times 50 \times 10^{-3}} = 2.93 \times 10^7 \text{ m s}^{-1}$$

$$\text{time taken, } t = \frac{L}{v} = \frac{60.0 \times 10^{-3}}{2.93 \times 10^7} = 2.05 \times 10^{-9} \text{ s}$$

$$\text{acceleration, } a = \frac{2y}{t^2} = \frac{2 \times 22.0 \times 10^{-3}}{(2.05 \times 10^{-9})^2} = 1.05 \times 10^{16} \text{ m s}^{-2}$$

$$e/m = \frac{ad}{V_p} = \frac{1.05 \times 10^{16} \times 50 \times 10^{-3}}{3000} = 1.75 \times 10^{11} \text{ C kg}^{-1}$$

Using the magnetic field only, with electrons of known speed v , the radius of curvature r of the beam path must be measured in a magnetic field of known flux density B .

Rearranging the equation $r = \frac{mv}{Be}$ from Topic 1.2 gives $\frac{e}{m} = \frac{v}{Br}$. Using the measured values of

$\frac{v}{Br}$ then enables $\frac{e}{m}$ to be calculated.

Note

The radius of curvature of the beam may be calculated using $r = \frac{(L^2 + y^2)}{2y}$. Knowledge or use of this formula is not required in the specification for this option.

Worked example

Electrons moving at a speed of $1.60 \times 10^7 \text{ m s}^{-1}$ are directed into a uniform magnetic field of flux density $1.40 \times 10^{-3} \text{ T}$ in such a direction as to form a circle of diameter 65 mm. Calculate the specific charge, e/m , of the electron.

Solution

$$e/m = \frac{v}{Br} = \frac{1.60 \times 10^7}{1.40 \times 10^{-3} \times 0.065} = 1.76 \times 10^{11} \text{ C kg}^{-1}$$

Measurement of e/m using the fine beam tube

The ‘fine beam’ tube shown in Figure 2 is designed to make the beam visible as a result of collisions between some of the electrons in the beam and the small amount of gas in the tube. The amount of gas is small enough so that most electrons are unaffected by its presence in the tube. With a sufficiently strong magnetic field, provided the initial direction of the beam is at right angles to the magnetic field lines, the beam path can be seen as a complete circle, enabling its diameter and its radius to be measured. Details of the measurement of the magnetic flux density are not required in the specification for this option.

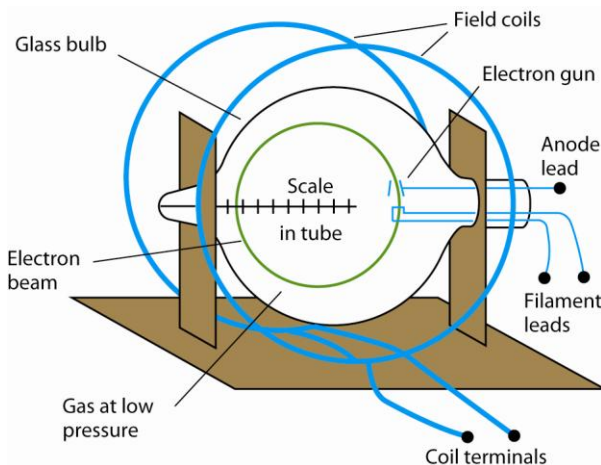

Figure 2 The fine beam tube

The stronger the field, the smaller the circle. With the anode voltage V_A constant, the coil current is adjusted in steps so the beam diameter can be measured directly from a scale inside the tube. In this way, the magnetic flux density B is measured for different values of the beam radius, r .

As explained in Topic 1.1, the speed of the electrons depends on the anode voltage, V_A , in accordance with the equation $\frac{1}{2} mv^2 = eV_A$.

Combining this with the equation $r = \frac{mv}{Be}$ rearranged as $v = \frac{Ber}{m}$ gives

$$\frac{1}{2} m \left(\frac{Be r}{m} \right)^2 = eV_A$$

Making $\frac{e}{m}$ the subject of this equation therefore gives

$$\frac{e}{m} = \frac{2V_A}{B^2 r^2}$$

Notes

- 1 Rearranging the above equation gives $r = k/B$ where the constant $k = \sqrt{\frac{2mV_A}{e}}$

Using the measurements of r and B to plot a graph of r against $\frac{1}{B}$ gives a straight line through

the origin with a gradient equal to k . Therefore, $\frac{e}{m}$ can be determined if the value of k is

measured from the graph and used in the equation $\frac{e}{m} = \frac{2V_A}{k^2}$

- 2 B can be measured using a Hall probe without the tube present. V_A is measured directly using a suitable voltmeter connected across the high voltage supply unit.

Worked example

Electrons emitted from the heated filament are accelerated through a pd of 490 V to form a beam which is then directed into a uniform magnetic field of magnetic flux density 3.4 mT. The magnetic field deflects the beam into a circle of diameter 44 mm. Use these data to calculate the specific charge of the electron.

Solution

beam radius $r = 22$ mm

$$e/m = \frac{2V_A}{B^2 r^2} = \frac{2 \times 490}{(3.4 \times 10^{-3} \times 22 \times 10^{-3})^2} = 1.75 \times 10^{11} \text{ C kg}^{-1}$$

The significance of Thomson's determination of e/m

The specific charge of the electron is $1.76 \times 10^{11} \text{ C kg}^{-1}$. The value was first determined by J J Thomson in 1895. Before Thomson made this measurement, the hydrogen ion was known to have the largest specific charge of any charged particle at $9.6 \times 10^7 \text{ C kg}^{-1}$. Thomson therefore showed that the electron's specific charge was 1860 times larger than that of the hydrogen ion. However, Thomson could not conclude that the electron has a much smaller mass than the hydrogen ion as neither the mass nor the charge of the electron was known at that time. The charge of the electron was measured by R A Millikan in 1915.

AQA Examiner's tip

Concentrate on the principles of the above methods and make sure you know when to use the relevant equations.

Summary questions

- 1** Electrons moving at a constant speed are directed horizontally into a uniform electric field due to two parallel plates of length 85.0 mm and spaced 40.0 mm apart which have a pd of 4000 V between them.
 - a** When a uniform magnetic field of flux density 2.95 mT is applied at right angles to the beam and to the electric field, the beam is undeflected. Calculate the speed of the electrons.
 - b** When the magnetic field is switched off, the beam is deflected vertically by the electric field by 55 mm where it leaves the field. Show that the each electron takes 2.51 ns to pass through the field and calculate the specific charge e/m of the electron.
- 2** Electrons moving at a speed of $1.35 \times 10^7 \text{ m s}^{-1}$ are directed into a uniform magnetic field of flux density $1.54 \times 10^{-3} \text{ T}$ in such a direction as to form a circle of diameter 50 mm. Calculate the specific charge, e/m , of the electron.
- 3** Electrons emitted from the heated filament are accelerated through a pd of 550 V to form a beam which is then directed into a uniform magnetic field of magnetic flux density 2.8 mT. The magnetic field deflects the beam into a circle of radius 28 mm. Use these data to calculate the specific charge of the electron.
- 4** Outline the significance of Thomson's determination of the specific charge of the electron, e/m .

1.4 The determination of the charge of the electron, e , by Millikan's method

Learning objectives:

- How can e be measured?
- What measurements are needed to determine e ?
- Why was Millikan's determination of e important?

Measurement of the charge of a charged oil droplet of known mass

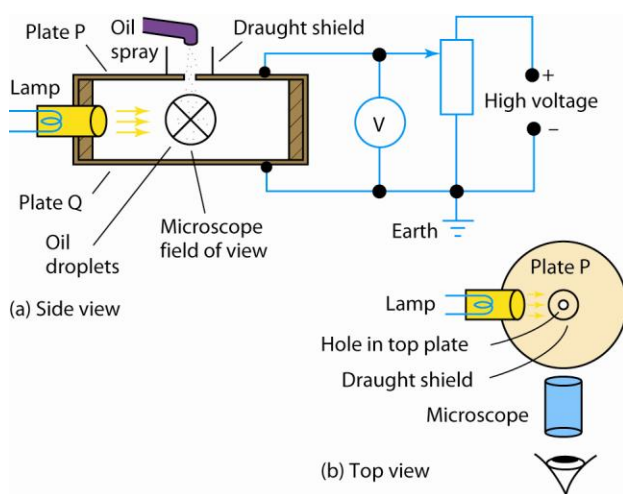

Figure 1 Millikan's method for finding e

The accurate measurement of the charge, e , of the electron was first successfully made by R A Millikan in 1915. He discovered he could control the motion of charged oil droplets from an oil spray using the electric field between oppositely charged parallel metal plates. He found that if the plates were horizontal so the field was vertical, he could slow down or stop or reverse the descent of an oil droplet falling between the plates. Using a microscope as shown in Figure 1, he was able to observe individual charged oil droplets.

He was able to make any charged droplet stay in a stationary position by adjusting the pd between the plates until the electric force on the droplet acting vertically upwards was equal and opposite to the weight of the droplet. Figure 2 shows the forces on such a charged droplet.

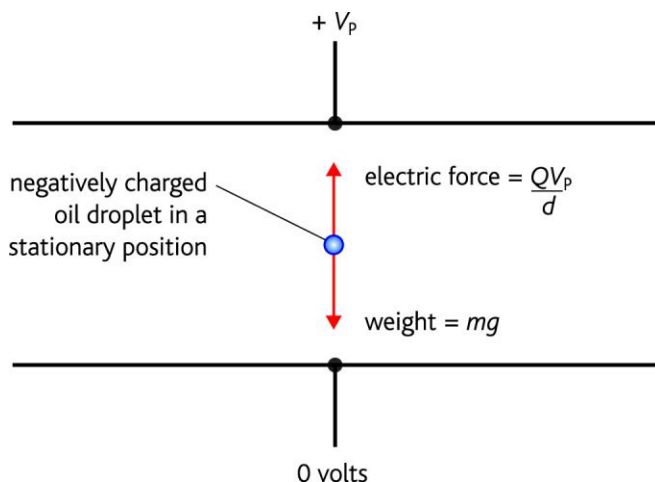

Figure 2 A stationary oil droplet

For a droplet of charge Q and mass m

- the electric force on the droplet $= \frac{QV_p}{d}$ where V_p is the plate pd and d is the perpendicular distance between the plates
- the weight of the droplet $= mg$

Therefore, when the droplet is stationary,

$$\frac{QV_p}{d} = mg$$

Hence the charge on the droplet $\frac{QV_p}{d} = \frac{mgd}{V_p}$

If the mass of the droplet is known, the charge Q on the droplet can therefore be calculated.

Notes

- 1 The polarity of the top plate must be opposite to the sign of the charge on the droplet in order that the force due to the electric field acts upwards. If the droplet is positive, the top plate must be negative with respect to the bottom plate. If the droplet is negative, the top plate must be positive with respect to the bottom plate.
- 2 The upthrust on the droplet due to buoyancy is equal to about 0.1% of its weight and therefore may be considered to be negligible. Knowledge of the upthrust is not required in this option specification.
- 3 The electric field strength between the plates $E = V_p/d$

The significance of Millikan's results

Millikan was able to measure the mass of each droplet accurately by measuring its terminal speed with the electric field switched off. He was then able to calculate its charge as explained above. After making many measurements on many charged oil droplets, he found that the charge Q was always a whole number $\times 1.6 \times 10^{-19}$ C. In other words, he showed that electric charge is **quantised** in whole number multiples of 1.6×10^{-19} C. He concluded that the charge of the electron is 1.6×10^{-19} C and that the whole number n corresponds to how many electrons on the droplet are responsible for its charge.

Worked example

$g = 9.81 \text{ m s}^{-2}$, $e = 1.6 \times 10^{-19} \text{ C}$

A charged oil droplet of mass $3.8 \times 10^{-15} \text{ kg}$ is held stationary by the electric field between two parallel horizontal metal plates which are 5.0 mm apart. The top plate is at a negative potential of -580 V relative to the lower plate which is earthed.

- a Calculate the charge on the droplet and state its sign.
- b State how many electrons are responsible for the droplet’s charge.

Solution

a $Q = \frac{mgd}{V_p} = \frac{3.8 \times 10^{-15} \times 9.81 \times 5.0 \times 10^{-3}}{580} = 3.2 \times 10^{-19} \text{ C}$

The droplet is positively charged.

- b 2

Measurement of the mass of an oil droplet

When no electric field is present, an oil droplet falls at its terminal speed according to its weight. The greater the weight of an oil droplet, the greater its terminal speed. Millikan realised the drag force on the droplet due to air resistance is equal and opposite to the weight of the droplet when it falls at terminal speed. The resultant force on it is zero and so its acceleration is zero. By measuring the terminal speed of the droplet, he was able to calculate the mass of the droplet as explained below.

Link

Terminal speed was looked at in Topic 9.3 of *AS Physics A*.

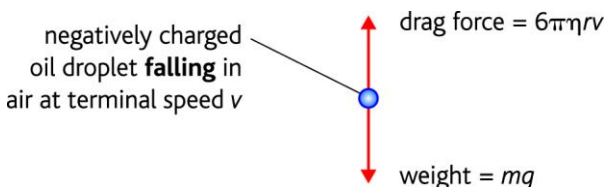

Figure 3 An oil droplet falling at terminal speed

Figure 3 shows the forces acting on the droplet as it falls at its terminal speed. Assuming the droplet is a sphere of radius r ,

- its volume = $\frac{4}{3} \pi r^3$ therefore its mass $m =$ its volume $(\frac{4}{3} \pi r^3) \times$ its density $(\rho) = \frac{4}{3} \pi r^3 \rho$.

Therefore, its weight $mg = \frac{4}{3} \pi r^3 \rho g$

- the drag force, $F_D = 6\pi\eta rv$ according to Stokes’ law, where η is the viscosity of air. The drag force is always in the opposite direction to its velocity.

So, $\frac{4}{3} \pi r^3 \rho g = 6\pi\eta rv$

Rearranging this equation gives $r^2 = \frac{9\eta v}{2\rho g}$

The equation above shows the radius r of the droplet and hence its mass can be calculated if its terminal speed v is measured and the values of the oil density ρ and the viscosity of air η are known.

Link

Density was looked at in Topic 11.1 of *AS Physics A*.

Worked example

density of the oil = 960 kg m^{-3} , viscosity of air = $1.8 \times 10^{-5} \text{ N s m}^{-2}$

A charged oil droplet was held stationary between oppositely charged metal plates 5.0 mm apart when the pd between the plates was 490 V. When the pd was switched off, the droplet fell at a terminal speed of $1.3 \times 10^{-4} \text{ m s}^{-1}$. Calculate:

- the mass of the droplet
- the charge of the droplet.

Solution

$$\text{a } r^2 = \frac{9\eta v}{2\rho g} = \frac{9 \times 1.8 \times 10^{-5} \times 1.3 \times 10^{-4}}{2 \times 960 \times 9.81} = 1.12 \times 10^{-12} \text{ m}^2 \text{ hence } r = 1.06 \times 10^{-6} \text{ m}$$

$$m = \frac{4}{3} \pi r^3 \rho = \frac{4}{3} \pi (1.06 \times 10^{-6})^3 \times 960 = 4.75 \times 10^{-15} \text{ kg}$$

$$\text{b } Q = \frac{mgd}{V_p} = \frac{4.75 \times 10^{-15} \times 9.81 \times 5.0 \times 10^{-3}}{490} = 4.8 \times 10^{-19} \text{ C}$$

Notes

- When the drop is held stationary by the electric field and the field is switched off, the droplet falls and reaches its terminal speed in a fraction of a second. Its initial acceleration is g as it is due to gravity only as the drag force is initially zero. As the droplet gains speed, the drag force increases so the resultant force (and hence the acceleration) decreases to zero.
- When the electric field is on and the droplet is moving vertically, it moves at a constant speed that depends on its weight, the drag force and the electric force. Figure 4 shows the forces acting on a droplet that is made to move up or down by changing the electric force.
 - In (a) the electric force is greater than the droplet weight so the droplet moves upwards.
 - In (b) the electric force is less than the weight so the droplet falls.
 - In (c) the electric force is downwards so the droplet falls.

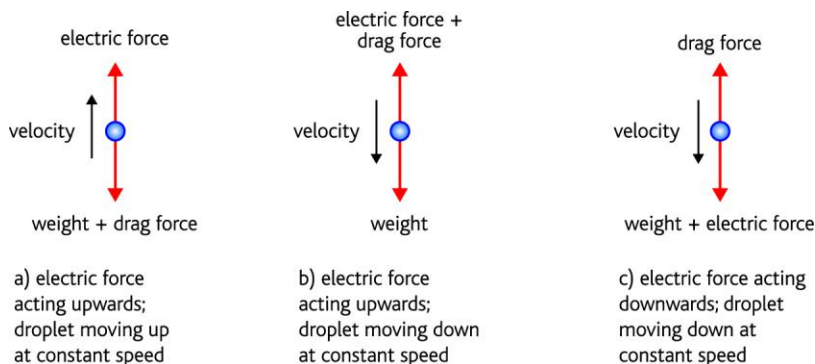

Figure 4 Using the electric field

AQA Examiner's tip

When describing the forces acting on the droplet, do not confuse 'electric force' with the term 'electric field'. The electric force is the force due to the electric field.

Summary questions

$g = 9.81 \text{ m s}^{-2}$, $e = 1.6 \times 10^{-19} \text{ C}$

- 1 A charged oil droplet of mass $2.60 \times 10^{-15} \text{ kg}$ is held stationary by the electric field between two parallel horizontal metal plates which are 6.00 mm apart. The top plate is at a positive potential of 320 V relative to the lower plate which is earthed.
 - a Calculate the charge on the droplet and state its sign.
 - b State how many electrons are responsible for the droplet's charge.
- 2 A charged oil droplet of radius $1.10 \times 10^{-6} \text{ m}$ is held stationary in a uniform electric field of strength $8.20 \times 10^4 \text{ V m}^{-1}$ which act vertically upwards.
 - a Show that the mass of the droplet is $5.35 \times 10^{-15} \text{ kg}$.
 - b i Calculate the charge on the droplet and state its sign.
ii State how many electrons are responsible for the droplet's charge.

density of oil = 960 kg m^{-3}
- 3 A charged oil droplet was held stationary between oppositely charged metal plates 5.00 mm apart when the pd between the plates was 610 V. When the pd was switched off, the droplet fell at a terminal speed of $1.15 \times 10^{-4} \text{ m s}^{-1}$. Calculate:
 - a the mass of the droplet
 - b the charge of the droplet.

density of the oil = 960 kg m^{-3} , viscosity of air = $1.80 \times 10^{-5} \text{ N s m}^{-2}$
- 4 a State the general result obtained by Millikan for the charge on a charged oil droplet and explain its significance.
b A charged oil droplet is held stationary in a uniform electric field which is then switched off. Describe and explain the subsequent motion of the droplet.